

“G” Series Shockless Type Solenoid Operated / Solenoid Controlled Pilot Operated Directional Valves

The G-Series Solenoid Operated Directional Valves incorporate electronic circuits to enable adjustment of the spool shifting time.

A special spool shape that minimises shock is used, shocks caused by the actuator starting and stopping, as well as vibration due to oil hammering. The shifting time of conventional Solenoid Operated, Shockless, and Directional Valves is constant and cannot be adjusted.

As the shifting time of the G-Series valves can be adjusted, it can be set at an optimal level to minimise shocks to the machine.

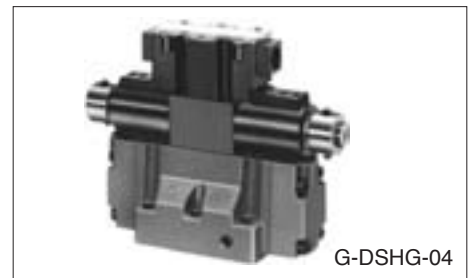

1 Reduces oil hammering during spool changeover.

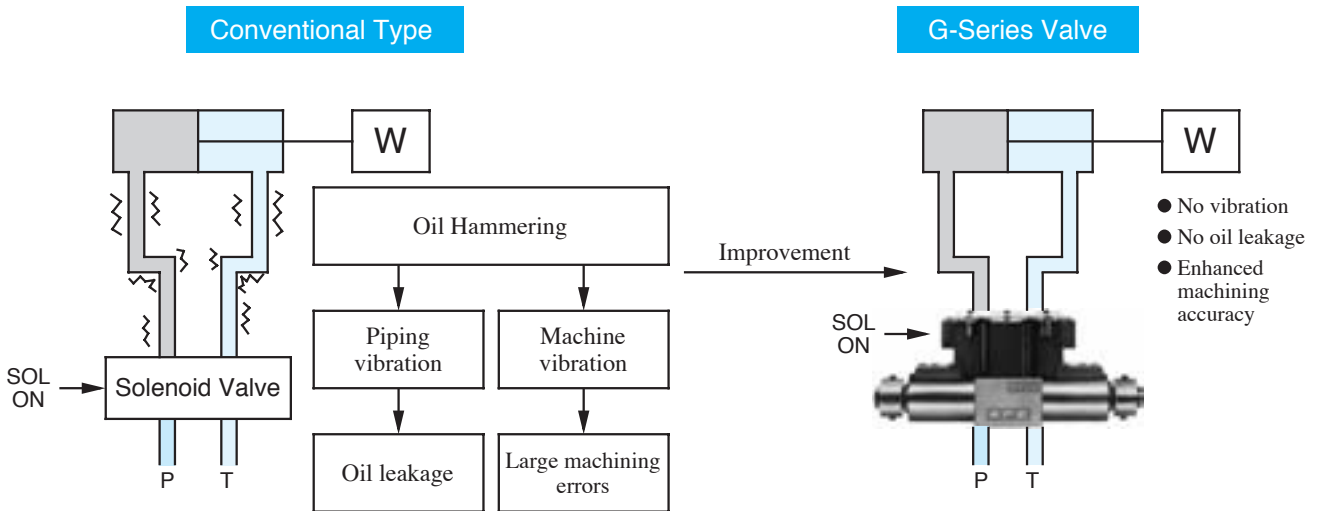

2 Reduces shock caused by acceleration and deceleration

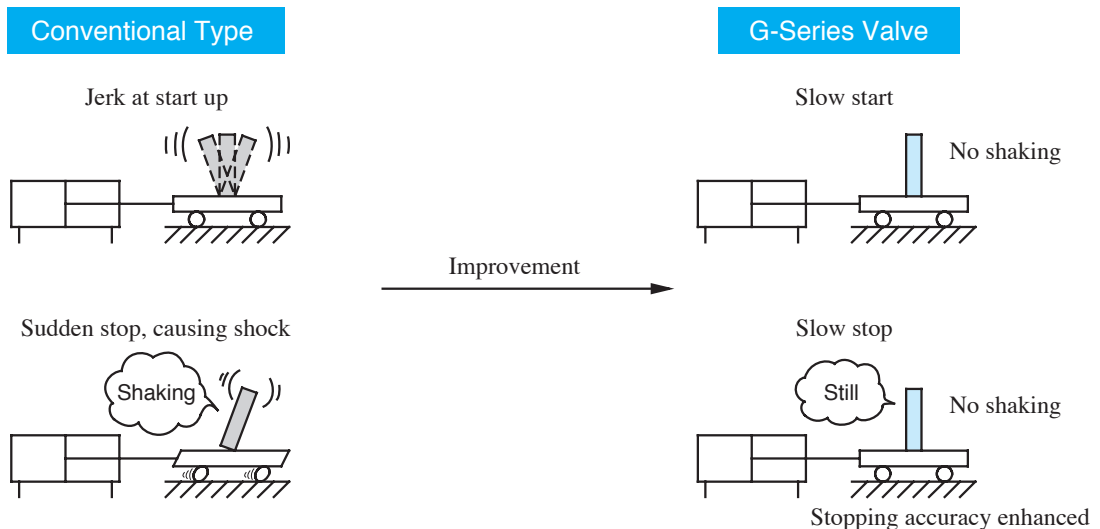

■ System Diagram (Example of sink type wiring)

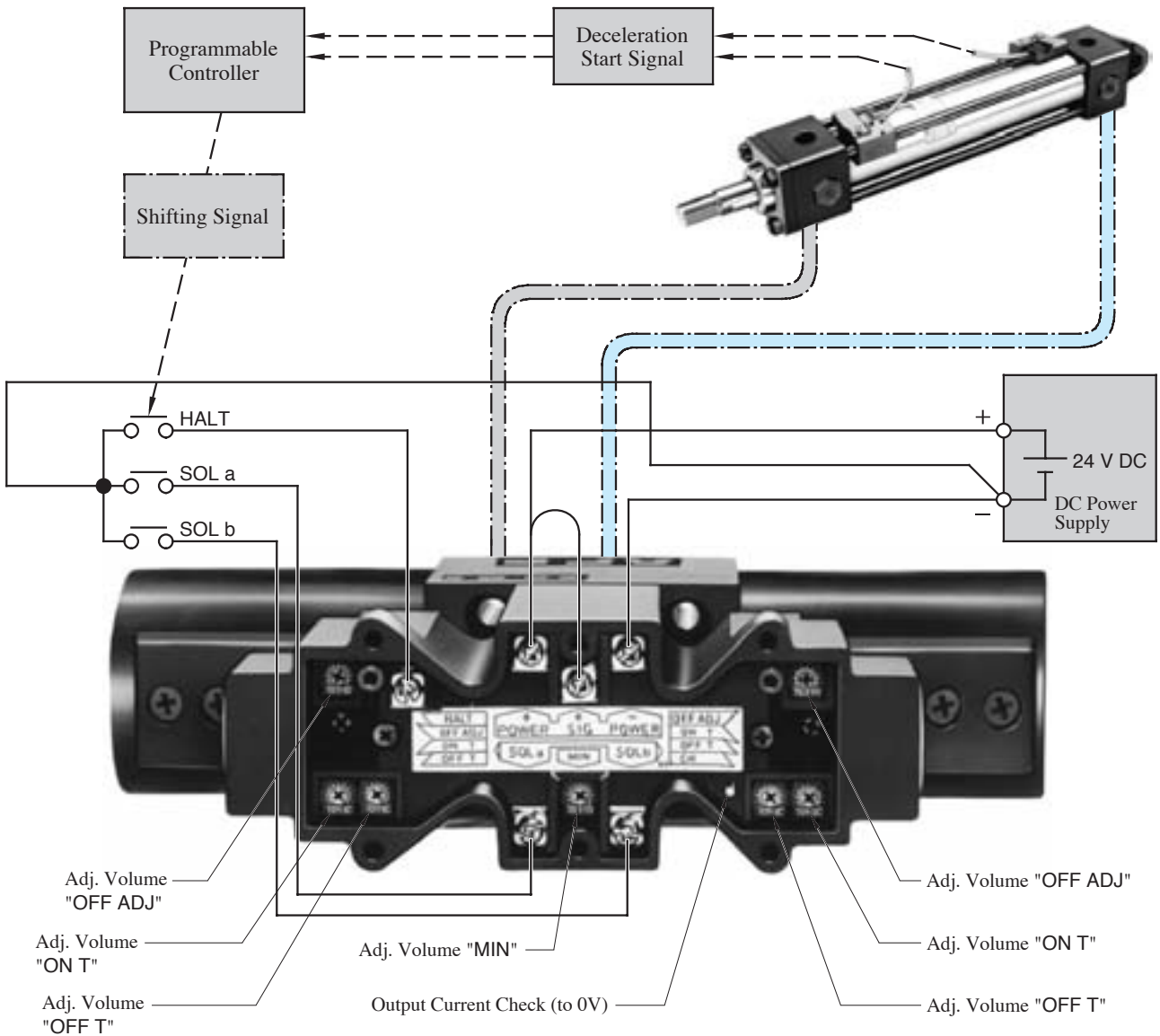

■ Relationships between SOL signals and flow patterns

● Without HALT functions

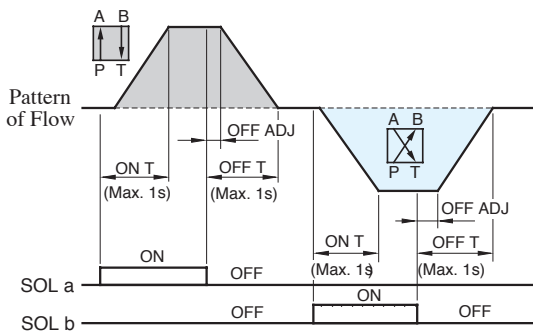

● With HALT functions

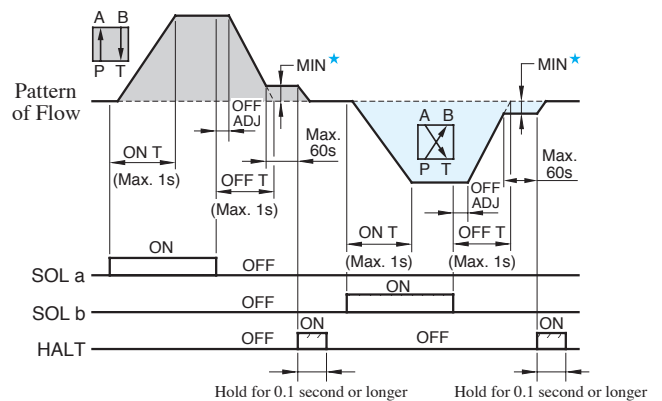

★ The minimum adjustment volume is common for SOL a and b, and it is not possible to set a different volume for each SOL a and b individually. If the HALT functions are not used, set the minimum adjustment volume to zero.

Instructions

Adjustment of maximum flow rate

The G-Series Solenoid Operated Directional Valves cannot be adjusted for maximum flow rates.

To adjust maximum flow rates, use flow control valves. In G-series solenoid controlled pilot operated directional valves (G-DSHG-04/06), the maximum flow rate can be adjusted by use of the valve with stroke adjustment screw of optional extra.

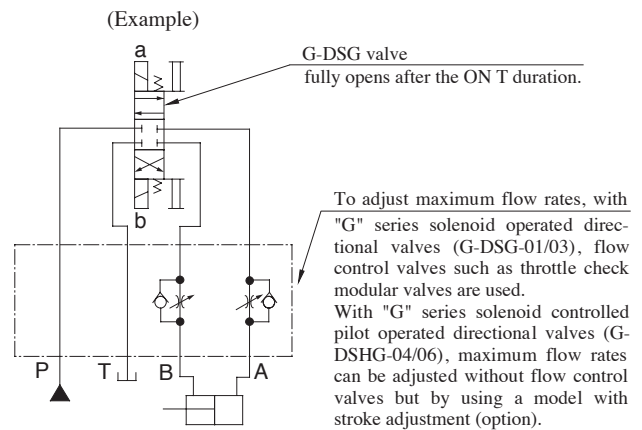

How to use HALT functions

The HALT functions are used to drive the actuator at a low speed to the stop position while keeping a slight flow after OFF T.

A flow rate (min. flow rate) during a low-speed operation can be set with the minimum adjusting volume (The minimum adjusting volume is common for SOL a and b. Individual setting is not possible for SOL a and b.) When HALT signal is on, the min. flow rate becomes zero and the actuator stops. Here, take care to keep the HALT signal on for longer than 0.1 second. The min. flow rate gets to "0" after about 60 seconds following the OFF T. If the HALT functions are not used, set the minimum adjusting volume to zero.

The HALT functions are not applicable to the spool function "2B7".

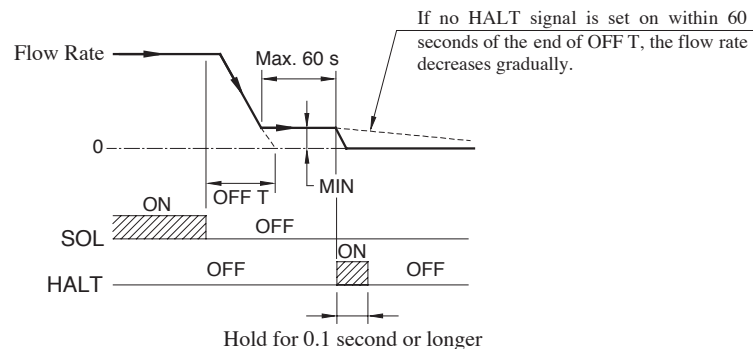

■ “G” Series Shockless Type Solenoid Operated Directional Valves

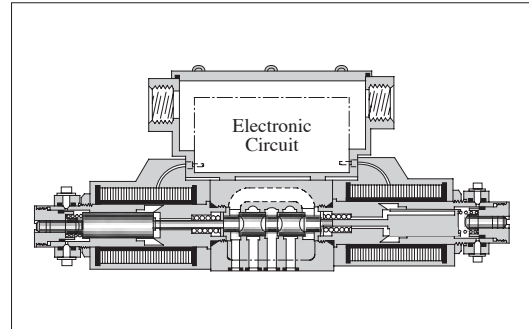



■ Specifications

Descriptions		Model Numbers	G-DSG-01-***-*-50/5090	G-DSG-03-***-*-50/5090
Max. Flow ^{★1}	L/min (U.S.GPM)		10 (2.6), 20 (5.3), 30 (7.9), 40 (10.6)	40 (10.6), 60 (15.9), 80 (21.1)
Max. Operating Pres. ^{★2}	MPa (PSI)		25 (3630)	25 (3630)
Max. T-Line Back Pres.	MPa (PSI)		16 (2320)	16 (2320)
Electric Power Supply	Voltage	24 V DC (21 - 28 V DC Included Ripple): Use a stable power supply		
	Input Power at 24V		36 W	36 W
Shifting signal, low speed operation halt signal (can be used in common with electric power supply).	Voltage	5 - 48 V DC (Use a stable power supply)		
	Current	Constant at 10 mA (A constant-current circuit is used)		
	Input interface	Sink Type, Source Type		
Shifting time range (for ON and OFF)			0.1 - 1 s	0.3 - 1 s
Low speed operation flow rate (min. flow rate) range (for SOL a and b) L/min (U.S.GPM)			0.5 - 5 (.13 - 1.3)	1 - 10 (.26 - 2.6)
Low speed operation flow rate (min. flow rate) hold time		Max. 60 s (After 60 seconds, the flow rate decreases gradually.)		
Ambient Temperature		0 - 50 °C (32 - 122 °F) with circulated air		
Approx. Mass	Single Solenoid		2.1 kg (4.6 lbs.)	5.3 kg (11.7 lbs.)
	Double Solenoid		3.0 kg (6.6 lbs.)	7.5 kg (16.5 lbs.)

★1. The maximum flow rates may vary according to the operating pressure. Refer to Maximum Flow Rates Characteristics on pages 414 and 415 for details.

★2. At pressures more than 21 MPa (3050 PSI), the "shockless effect" is slightly less if compared it with that at 16 MPa (2320 PSI).

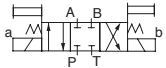
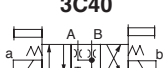
Model Number Designation

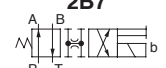
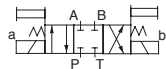
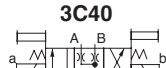
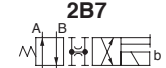
G-DSG	-01	-10	-2B7	-S	-50	*	-L
Series Number	Valve Size	Metred Flow Capacity	Spool Type	Input Interface	Design Number	Design Standards	Models with Alternate Offset Solenoid
G-DSG : G Series Shockless Type Solenoid Operated Directional Valve, Sub-plate Mounting	01	None: 40 L/min 10 : 10 L/min 20 : 20 L/min	3C2  3C40 	None: Sink Type (Standard) S: Source Type	50	Refer to ★	L Applicable only for 2B7 (Omit if not required) 
		None: 30 L/min 10 : 10 L/min 20 : 20 L/min	2B7 				
	03	None: 80 L/min 40 : 40 L/min 60 : 60 L/min	3C2  3C40 		50		
		None: 60 L/min 40 : 40 L/min	2B7 				

★ Design Standards: None Japanese Standard "JIS" and European Design Standard 90 N. American Design Standard

Sub-plate

Valve Model Numbers	Japanese Standard "JIS"		European Design Standard		N. American Design Standard		Approx. Mass kg (lbs.)
	Sub-plate Model Numbers	Thread Size	Sub-plate Model Numbers	Thread Size	Sub-plate Model Numbers	Thread Size	
G-DSG-01	DSGM-01-31	Rc 1/8	DSGM-01-3180	1/8 BSPF	DSGM-01-3190	1/8 NPT	0.8 (1.8)
	DSGM-01X-31	Rc 1/4	DSGM-01X-3180	1/4 BSPF	DSGM-01X-3190	1/4 NPT	0.8 (1.8)
	DSGM-01Y-31	Rc 3/8	—	—	DSGM-01Y-3190	3/8 NPT	0.8 (1.8)
G-DSG-03	DSGM-03-40	Rc 3/8	DSGM-03-2180	3/8 BSPF	DSGM-03-2190	3/8 NPT	3.0 (6.6)
	DSGM-03X-40	Rc 1/2	DSGM-03X-2180	1/2 BSPF	DSGM-03X-2190	1/2 NPT	3.0 (6.6)
	DSGM-03Y-40	Rc 3/4	DSGM-03Y-2180	3/4 BSPF	DSGM-03Y-2190	3/4 NPT	4.7 (10.4)

● Sub-plates are available. Specify the sub-plate model number from the table above. When sub-plates are not used, the mounting surface should have a good machined finish.

Attachment (Mtg. Bolt)

Four socket head cap screws in the table below are included.

Model Numbers	Socket Head Cap Screw (4 pcs.)		
	Japanese Standard "JIS" & European Design Standard	N. American Design Standard	Tightening Torque
G-DSG-01	M5 × 45 Lg.	No.10-24 UNC × 1-3/4 Lg.	5-7 Nm (44-62 in. lbs.)
G-DSG-03	M6 × 35 Lg.	1/4-20 UNC × 1-1/2 Lg.	12-15 Nm (106-133 in. lbs.)

Typical Performance Characteristics of "G-DSG-01" at Viscosity 30 mm²/s (141 SSU), Specific Gravity 0.850

■ Maximum Flow Rate

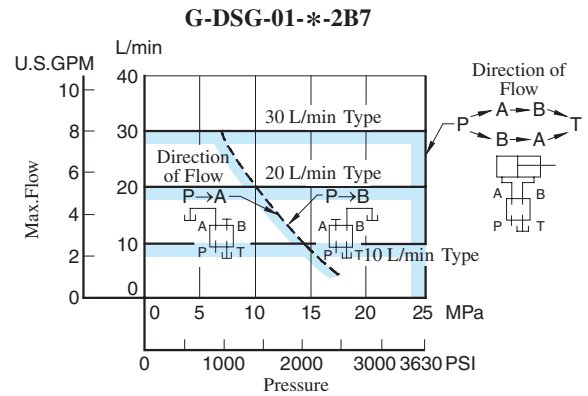
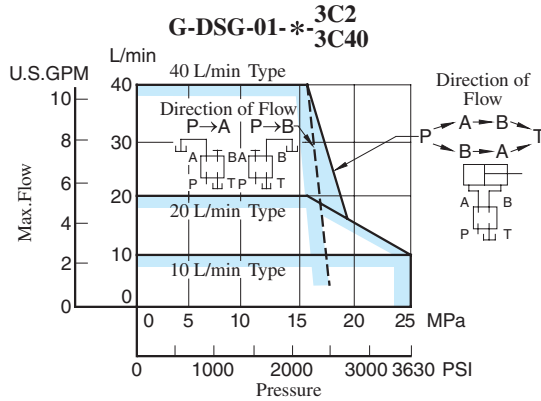

■ Pressure Drop

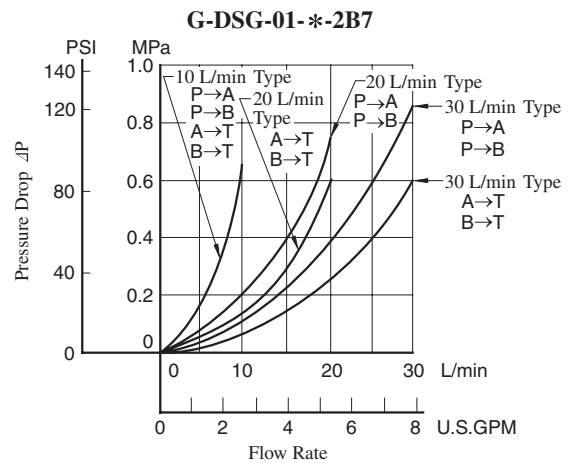
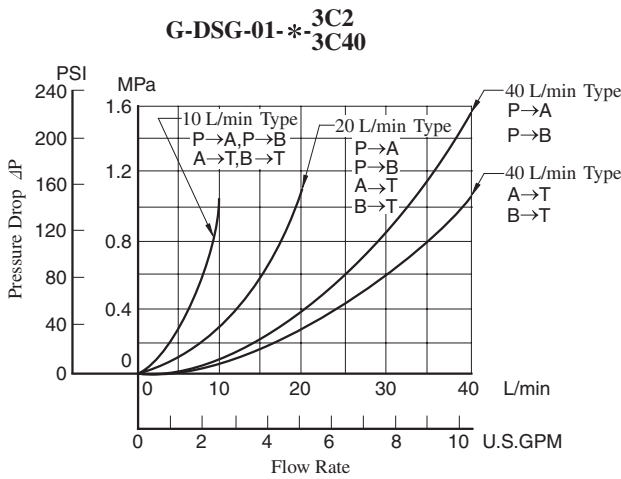

- For any other viscosity, multiply the factors in the table right.
- For any other specific gravity (G'), the pressure drop (ΔP') may be obtained from the formula below.

$$\Delta P' = \Delta P (G'/0.850)$$

Viscosity	mm ² /s	15	20	30	40	50	60	70	80	90	100
		SSU	77	98	141	186	232	278	324	371	417
Factor		0.84	0.91	1.00	1.07	1.14	1.19	1.24	1.28	1.32	1.35

■ Shifting Characteristics

Supply Pressure : 16 MPa (2320 PSI)
Flow Rate : 30 L/min (7.9 U.S.GPM)

● 3C2, 3C40

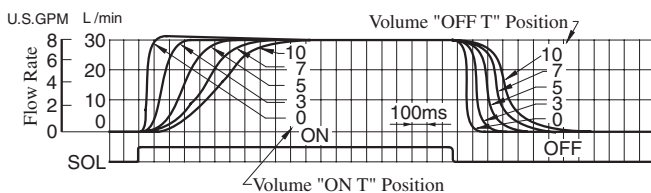

● 2B7

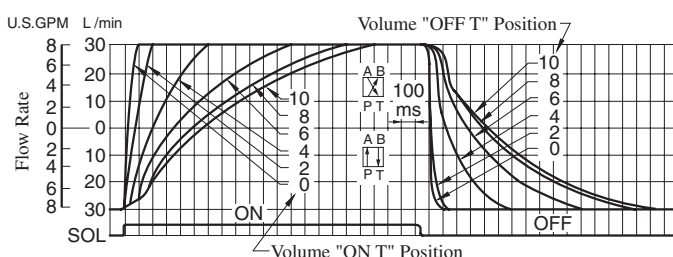

■ Low Speed Operating Flow Characteristics

Supply Pressure : 16 MPa (2320 PSI)
Flow Rate : 30 L/min (7.9 U.S.GPM)

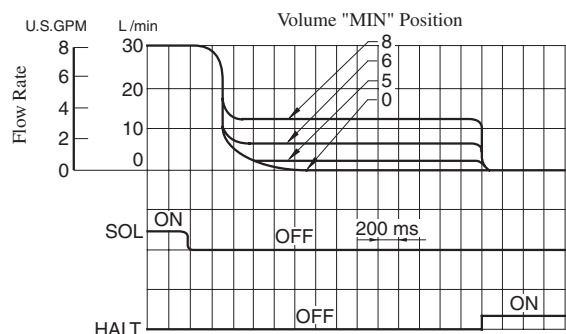

Typical Performance Characteristics of "G-DSG-03" at Viscosity 30 mm²/s (141 SSU), Specific Gravity 0.850

Maximum Flow Rate

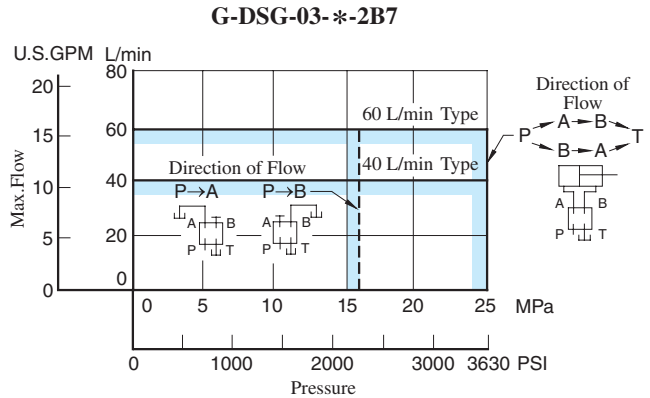
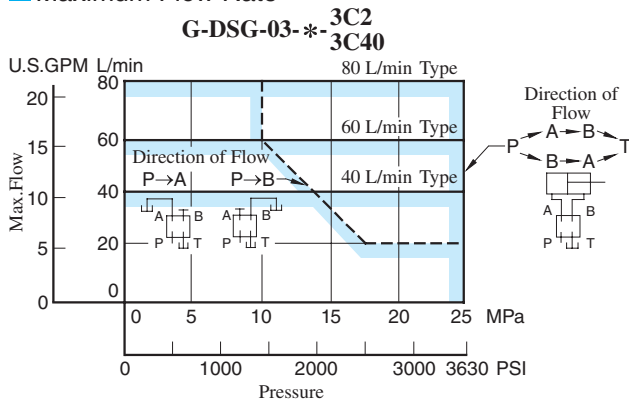

Pressure Drop

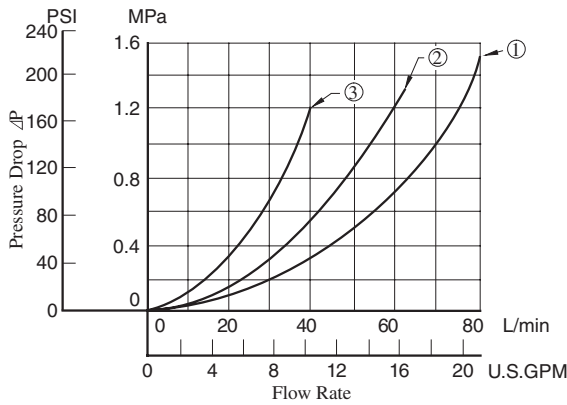

Model Numbers	Pressure Drop Curve Numbers*
G-DSG-03- ^{3C2} _{3C40}	①
G-DSG-03-40- ^{3C2} _{3C40}	③
G-DSG-03-60- ^{3C2} _{3C40}	②
G-DSG-03-2B7	①
G-DSG-03-40-2B7	③

* The numbers of the pressure drop curves are the same for P→A, P→B, A→T and B→T.

- For any other viscosity, multiply the factors in the table right.
- For any other specific gravity (G'), the pressure drop (ΔP') may be obtained from the formula below.

$$\Delta P' = \Delta P (G'/0.850)$$

Viscosity	mm ² /s	15	20	30	40	50	60	70	80	90	100
	SSU	77	98	141	186	232	278	324	371	417	464
Factor		0.84	0.91	1.00	1.07	1.14	1.19	1.24	1.28	1.32	1.35

Shifting Characteristics

Supply Pressure : 16 MPa (2320 PSI)
Flow Rate : 60 L/min (15.9 U.S.GPM)

● 3C2, 3C40

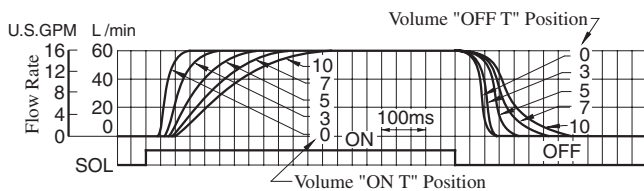

● 2B7

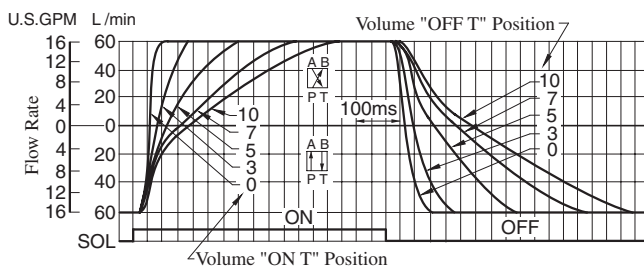

Low Speed Operating Flow Characteristics

Supply Pressure : 16 MPa (2320 PSI)
Flow Rate : 60 L/min (15.9 U.S.GPM)

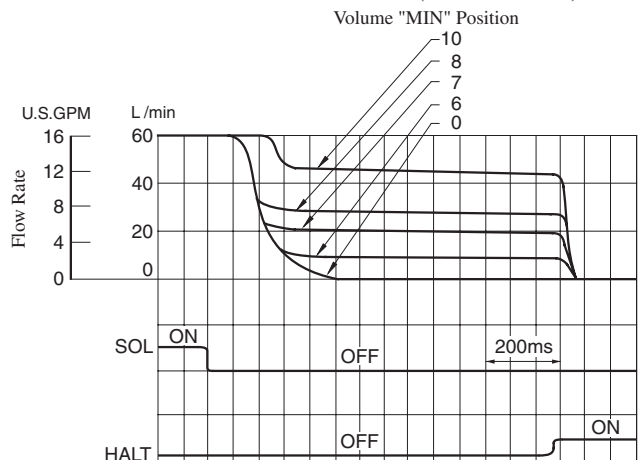

G-DSG-01-**-3C2/3C40-**-50/5090

Mounting Surface:
ISO4401-AB-03-4-A

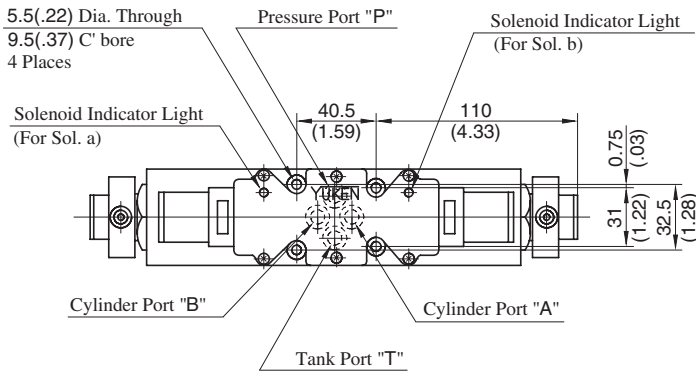

Model Numbers	"C" Thd.
G-DSG-01-***-50	G 1/2
G-DSG-01-***-5090	1/2 NPT

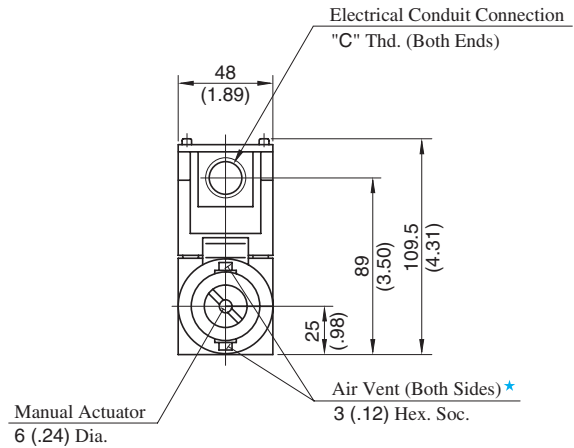
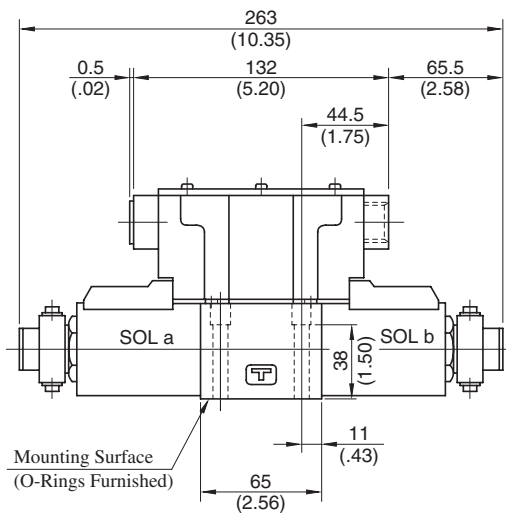

★ Air vent position around valve longitudinal axis can be optionally selected.

Note: For the valve mounting surface dimensions, see the dimensional drawing of the sharable sub-plate in [page 356](#).

**DIMENSIONS IN
MILLIMETRES (INCHES)**

G-DSG-01-**-2B7-**-50/5090

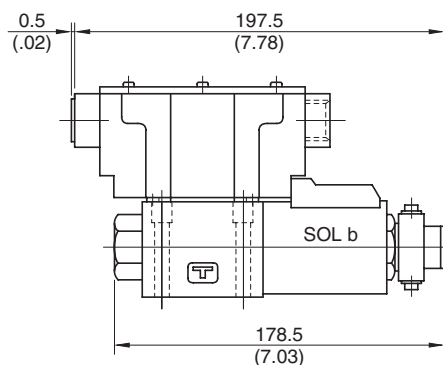

• For other dimensions, refer to the drawing above.

G-DSG-03-**-3C2/3C40-**-50/5090

Mounting Surface:
ISO 4401-AC-05-4-A

Model Numbers	"C" Thd.
G-DSG-03-**-50	G 1/2
G-DSG-03-**-5090	1/2 NPT

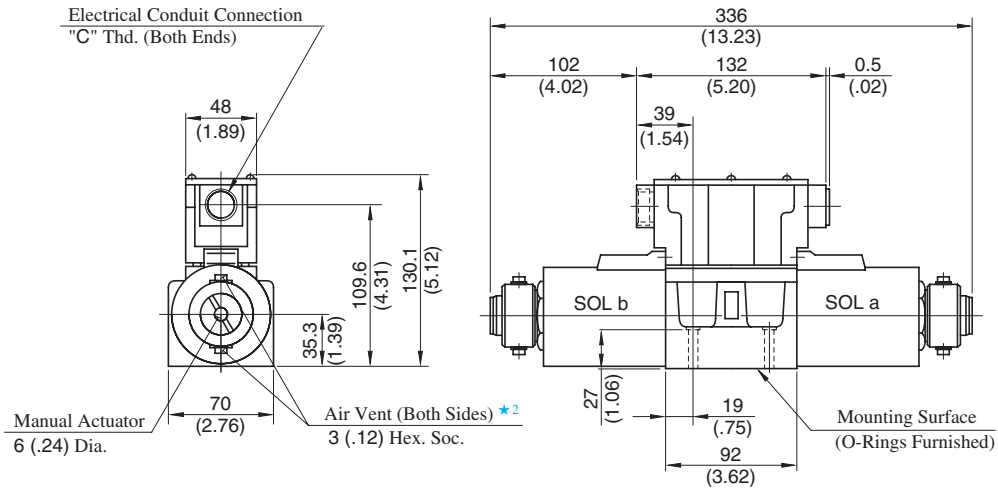
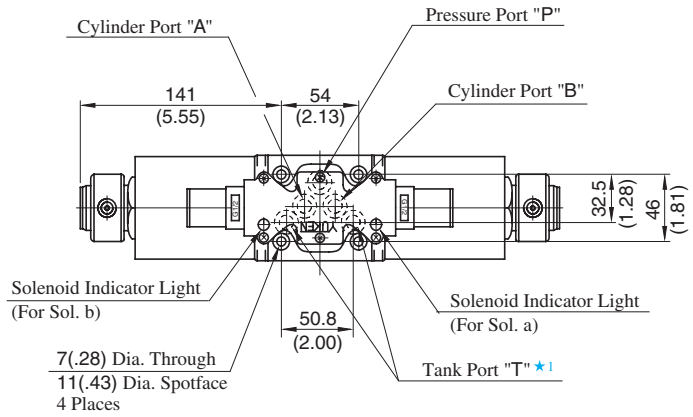

- ★ 1. Although the tank port is shown on the left in our sub-plate, either may be used.
 - ★ 2. Air vent position around valve longitudinal axis can be optionally selected.
- Note: For the valve mounting surface dimensions, see the dimensional drawing of the sharable sub-plate in [page 373](#).

DIMENSIONS IN
MILLIMETRES (INCHES)

G-DSG-03-**-2B7-**-50/5090

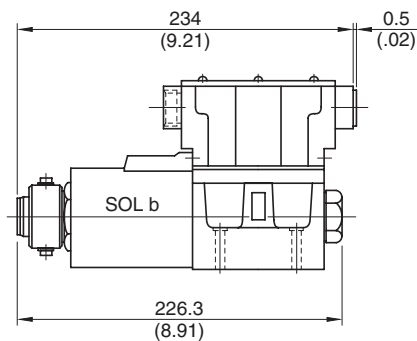

- For other dimensions, refer to the drawing above.

E

"G" Series Shockless Type Solenoid Operated Directional Valves

■ “G” Series Shockless Type Solenoid Controlled Pilot Operated Directional Valves

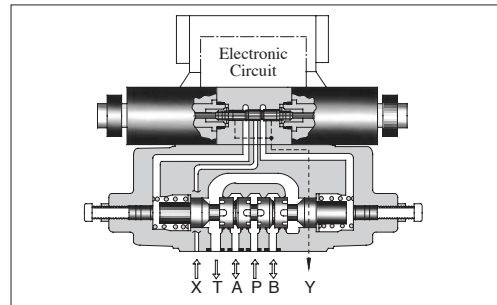



■ Specifications

Descriptions		Model Numbers	G-DSHG-04-3C*-**-50/5090	G-DSHG-06-3C*-**-50/5090
Max. Flow	L/min (U.S.GPM)		160 (42.3) ★ ¹	250 (66.1) ★ ¹
Max. Operating Pres.	MPa (PSI)		25 (3630)	25 (3630)
Max. T-Line Back Pres.	MPa (PSI)		16 (2320)	16 (2320)
Max. Drain Line Back Pressure	MPa (PSI)		3 (440)	3 (440)
Max. Pilot Pressure	MPa (PSI)		16 (2320)	16 (2320)
Min. Required Pilot Pres.	MPa (PSI)		1.5 (220) ★ ²	
Pilot Flow L/min (U.S.GPM)	at Normal		1 (0.3)	1 (0.3)
	at Transition		4 (1.1)	6 (1.6)
Electric Power Supply	Voltage		24 V DC (21 - 28 V DC Included Ripple): Use a stable power supply	
	Input Power at 24V		36 W	36 W
Shifting signal, low speed operation halt signal (can be used in common with electric power supply)	Voltage		5 - 48 V DC (Use a stable power supply)	
	Current		Constant at 10 mA (A constant-current circuit is used)	
	Input interface		Sink Type, Source Type	
Shifting time range (for ON and OFF)			ON: 0.06 - 1.5 s, OFF: 0.1 - 2 s	ON: 0.1 - 1 s, OFF: 0.2 - 2 s
Low speed operation flow rate (min. flow rate) range (for SOL a and b)	L/min (U.S.GPM)		5 - 20 (1.3 - 5.3)	10 - 30 (2.6 - 7.9)
Low speed operation flow rate (min. flow rate) hold time			Max. 60 s (After 60 seconds, the flow rate decreases gradually.)	
Ambient Temperature			0 - 50 °C (32 - 122 °F) with circulated air	
Approx. Mass			12 kg (26.5 lbs.)	15 kg (33.1 lbs.)

★1. The maximum flow rate is constant irrespective of the working pressure.

★2. Be sure that the difference between pilot pressure and drain port back pressure is larger than the minimum pilot pressure.

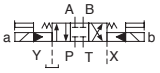
Model Number Designation

G-DSHG	-04	-3C2	-E	-R2	-S	-50	*
Series Number	Valve Size	Spool Type	Pilot Connection	Spool Control Modification (Omit if not required)	Input Interface	Design Number	Design Standards
G-DSHG : G Series Shockless Type Solenoid Controlled Pilot Operated Directional Valve, Sub-plate Mounting	04	3C2 	None: Internal Pilot	R2: With Stroke Adjustment, Both Ends RA: With Stroke Adjustment, Port "A" End RB: With Stroke Adjustment, Port "B" End	None: Sink Type (Standard) S: Source Type	50	Refer to ★
	06	3C40 	E: External Pilot			50	

★ Design Standards: None Japanese Standard "JIS" and European Design Standard 90 N. American Design Standard

Sub-plate

Valve Model Numbers	Japanese Standard "JIS"			European Design Standard			N. American Design Standard		
	Sub-plate Model Numbers	Thread Size	Approx. Mass kg (lbs.)	Sub-plate Model Numbers	Thread Size	Approx. Mass kg (lbs.)	Sub-plate Model Numbers	Thread Size	Approx. Mass kg (lbs.)
G-DSHG-04	DHGM-04-20	Rc 1/2	4.4 (9.7)	DHGM-04-2080	1/2 BSP.F	4.4 (9.7)	DHGM-04-2090	1/2 NPT	4.4 (9.7)
	DHGM-04X-20	Rc 3/4	4.1 (9.0)	DHGM-04X-2080	3/4 BSP.F	4.1 (9.0)	DHGM-04X-2090	3/4 NPT	4.1 (9.0)
G-DSHG-06	DHGM-06-50	Rc 3/4	7.4 (16.3)	DHGM-06-5080	3/4 BSP.F	8.5 (18.7)	DHGM-06-5090	3/4 NPT	7.4 (16.3)
	DHGM-06X-50	Rc 1	7.4 (16.3)	DHGM-06X-5080	1 BSP.F	8.5 (18.7)	DHGM-06X-5090	1 NPT	7.4 (16.3)

● Sub-plates are available. Specify the sub-plate model number from the table above. When sub-plates are not used, the mounting surface should have a good machined finish.

Attachment (Mtg. Bolts)

Socket head cap screws in the table below are included.

Model Numbers	Socket Head Cap Screw			
	Japanese Standard "JIS" & European Design Standard	N. American Design Standard	Qty.	Tightening Torque Nm (in. lbs.)
G-DSHG-04	M6 × 45 Lg.	1/4-20 UNC × 1-3/4 Lg.	2	12-15 (106-133)
	M10 × 50 Lg.	3/8-16 UNC × 2 Lg.	4	58-72 (513-637)
G-DSHG-06	M12 × 60 Lg.	1/2-13 UNC × 2-1/2 Lg.	6	100-123 (885-1089)

E

"G" Series Shockless Type Solenoid Controlled Pilot Directional Valves

Hydraulic Fluid: Viscosity 30 mm²/s (141 SSU), Specific Gravity 0.850

Pressure Drop

G-DSHG-04/06-3C2/3C40

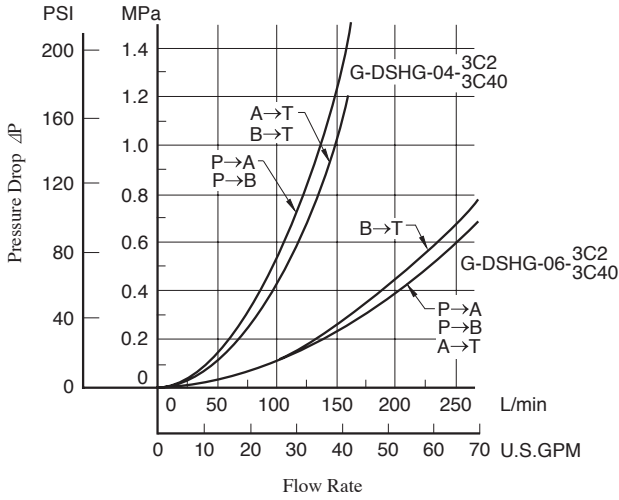

For any other viscosity, multiply the factors in the table below.

Viscosity	mm ² /s	15	20	30	40	50	60	70	80	90	100
	SSU	77	98	141	186	232	278	324	371	417	464
Factor		0.84	0.91	1.00	1.07	1.14	1.19	1.24	1.28	1.32	1.35

For any other specific gravity (G'), the pressure drop (ΔP') may be obtained from the formula below.
 $\Delta P' = \Delta P (G'/0.850)$

Shifting Characteristics

G-DSHG-04-3C2/3C40

Supply Pressure : 16 MPa (2320 PSI)
 Flow Rate : 150 L/min (39.6 U.S.GPM)
 Pilot Pressure : 16 MPa (2320 PSI)

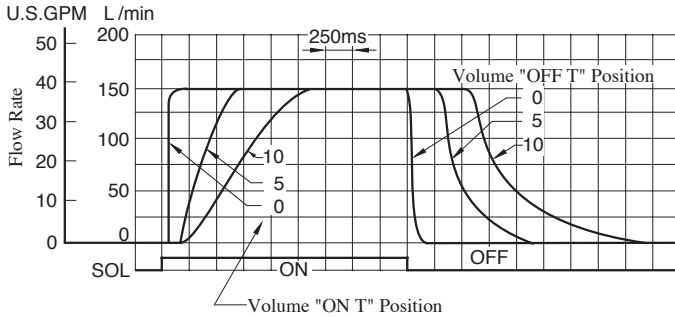

G-DSHG-06-3C2/3C40

Supply Pressure : 16 MPa (2320 PSI)
 Flow Rate : 250 L/min (66.1 U.S.GPM)
 Pilot Pressure : 16 MPa (2320 PSI)

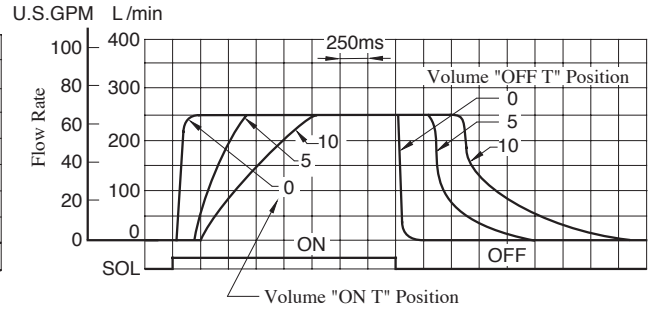

Low Speed Operating Flow Characteristics

G-DSHG-04-3C2/3C40

Supply Pressure : 16 MPa (2320 PSI)
 Flow Rate : 150 L/min (39.6 U.S.GPM)
 Pilot Pressure : 16 MPa (2320 PSI)

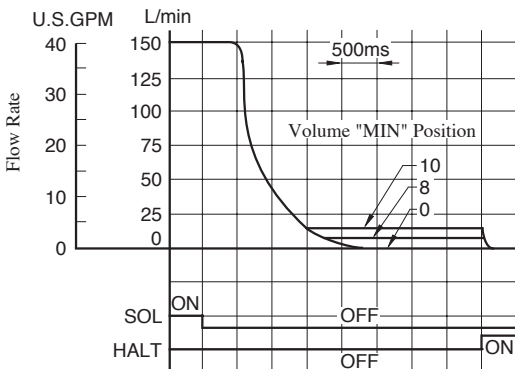

G-DSHG-06-3C2/3C40

Supply Pressure : 16 MPa (2320 PSI)
 Flow Rate : 250 L/min (66.1 U.S.GPM)
 Pilot Pressure : 16 MPa (2320 PSI)

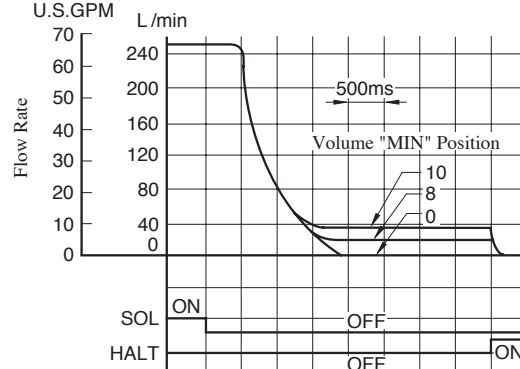

G-DSHG-04-3C*-**-50/5090

Mounting Surface:
ISO 4401-AD-07-4-A

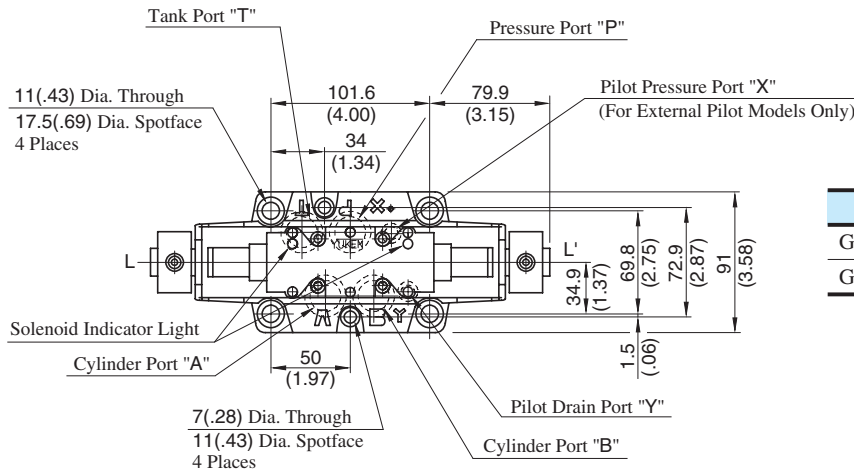

Model Numbers	"C" Thd.
G-DSHG-04-3C*-**-50	G 1/2
G-DSHG-04-3C*-**-5090	1/2 NPT

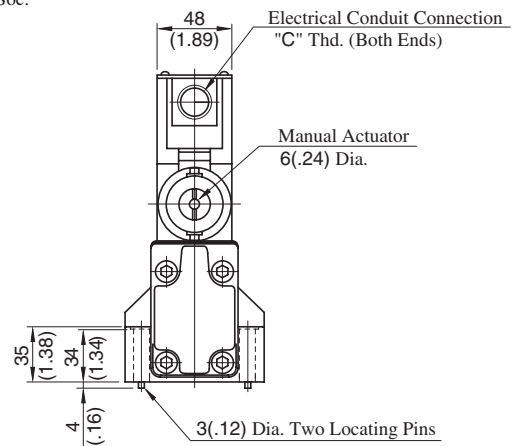
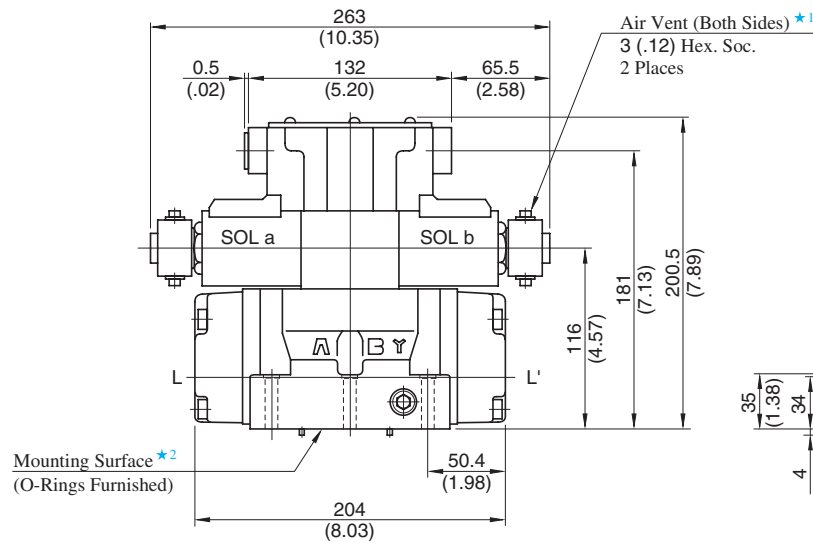

- ★ 1. Air vent position around valve longitudinal axis can be optionally selected.
- ★ 2. O-rings for ports: SO-NB-P22 for P/A/B/T ports
SO-NB-P9 for X/Y ports

Note: For the valve mounting surface dimensions, see the dimensional drawing of the sharable sub-plate on [page 401](#).

DIMENSIONS IN
MILLIMETRES (INCHES)

● Models with Stroke Adjustment (Option)

G-DSHG-04-3C*-**-R*-**-50/5090

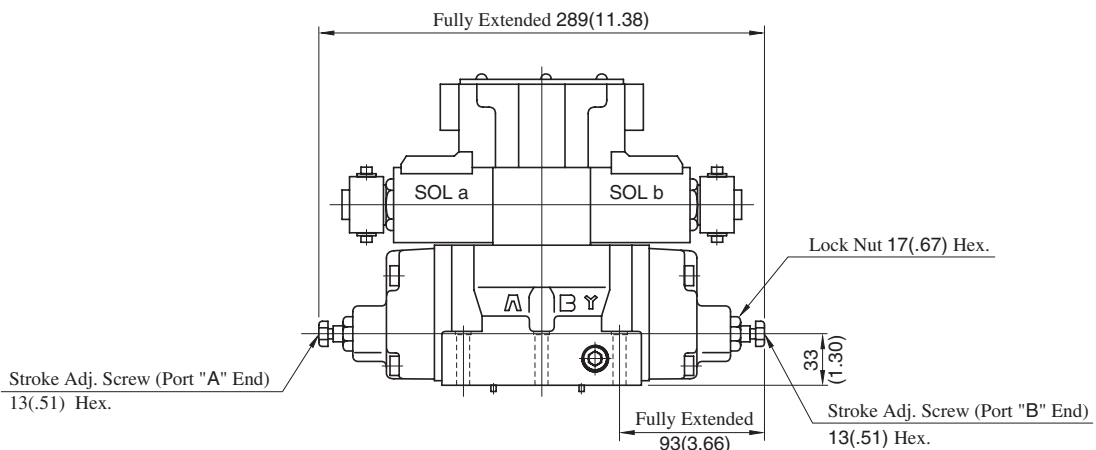

G-DSHG-06-3C*-*-50/5090

Mounting Surface:
ISO4401-AE-08-4-A

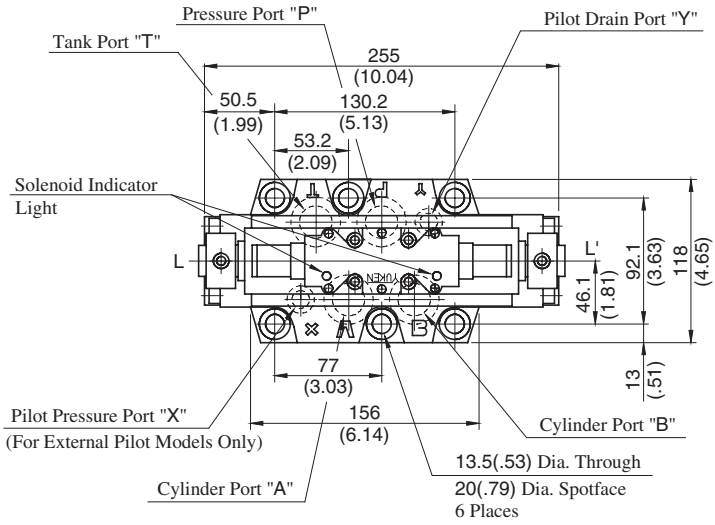

Model Numbers	"C" Thd.
G-DSHG-06-3C*-*-50	G 1/2
G-DSHG-06-3C*-*-5090	1/2 NPT

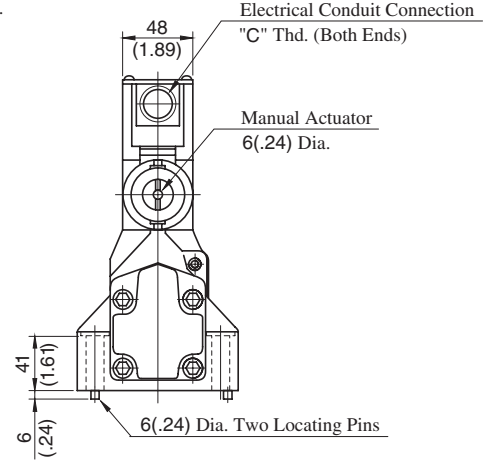
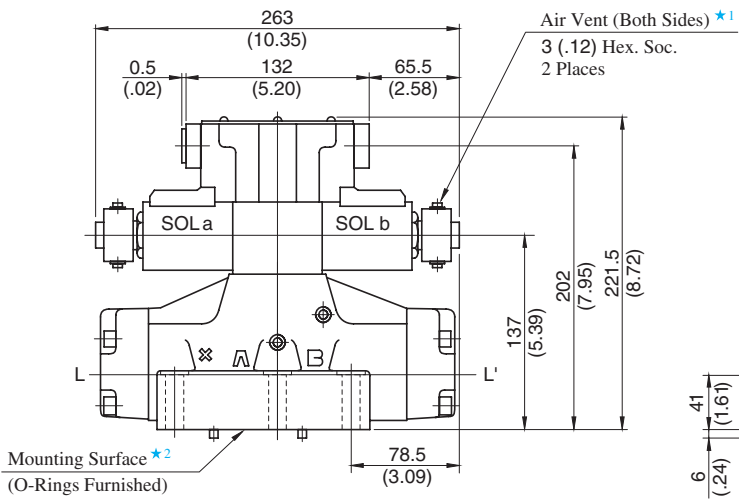

- ★ 1. Air vent position around valve longitudinal axis can be optionally selected.
 - ★ 2. O-rings for ports: SO-NB-P30 for P/A/B/T ports
SO-NB-P14 for X/Y ports
- Note: For the valve mounting surface dimensions, see the dimensional drawing of the sharable sub-plate in [page 403](#).

DIMENSIONS IN
MILLIMETRES (INCHES)

● **Models with Stroke Adjustment (Option)**

G-DSHG-06-3C*-*-R*-50/5090

